

REVISIONS					
P	LTR	DESCRIPTION	DATE	DMN	APVD
S		REVISED PER ECO-15-015252	12NOV15	BJ	FY

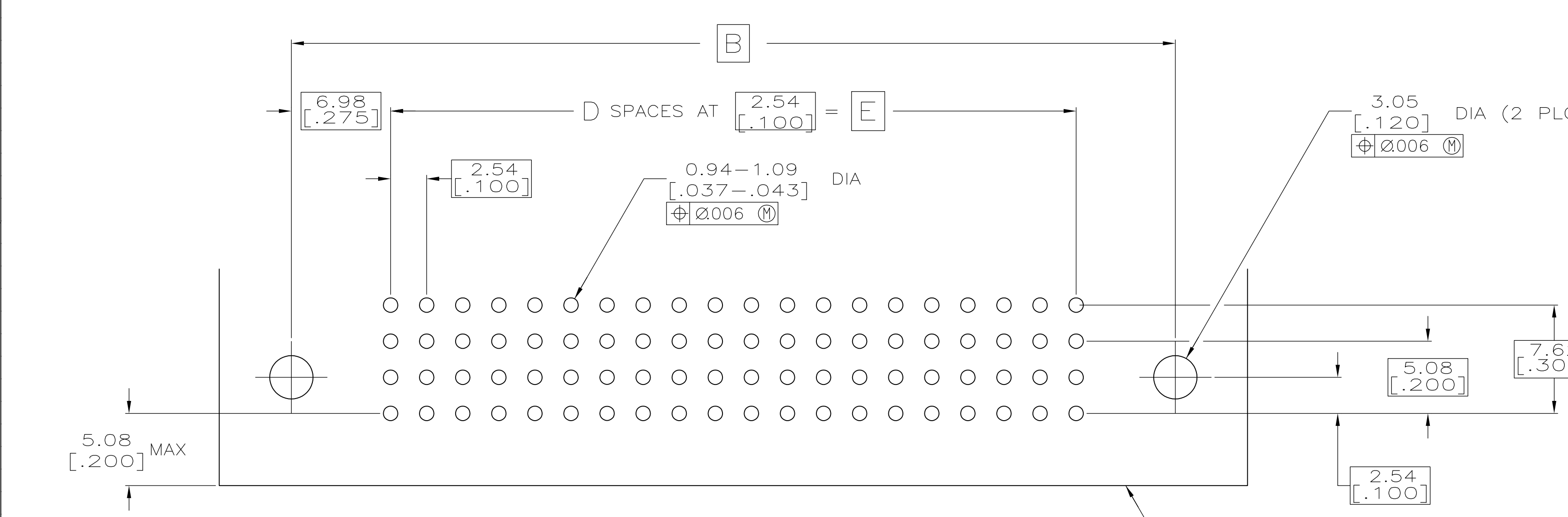
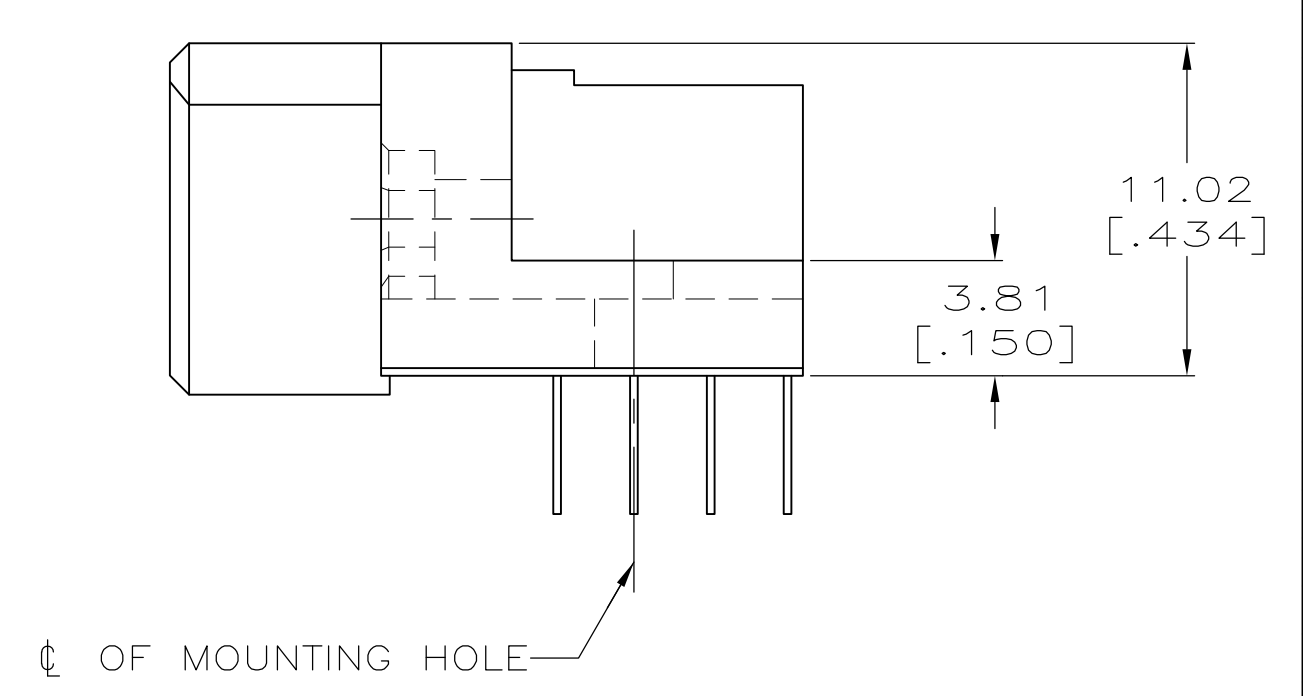
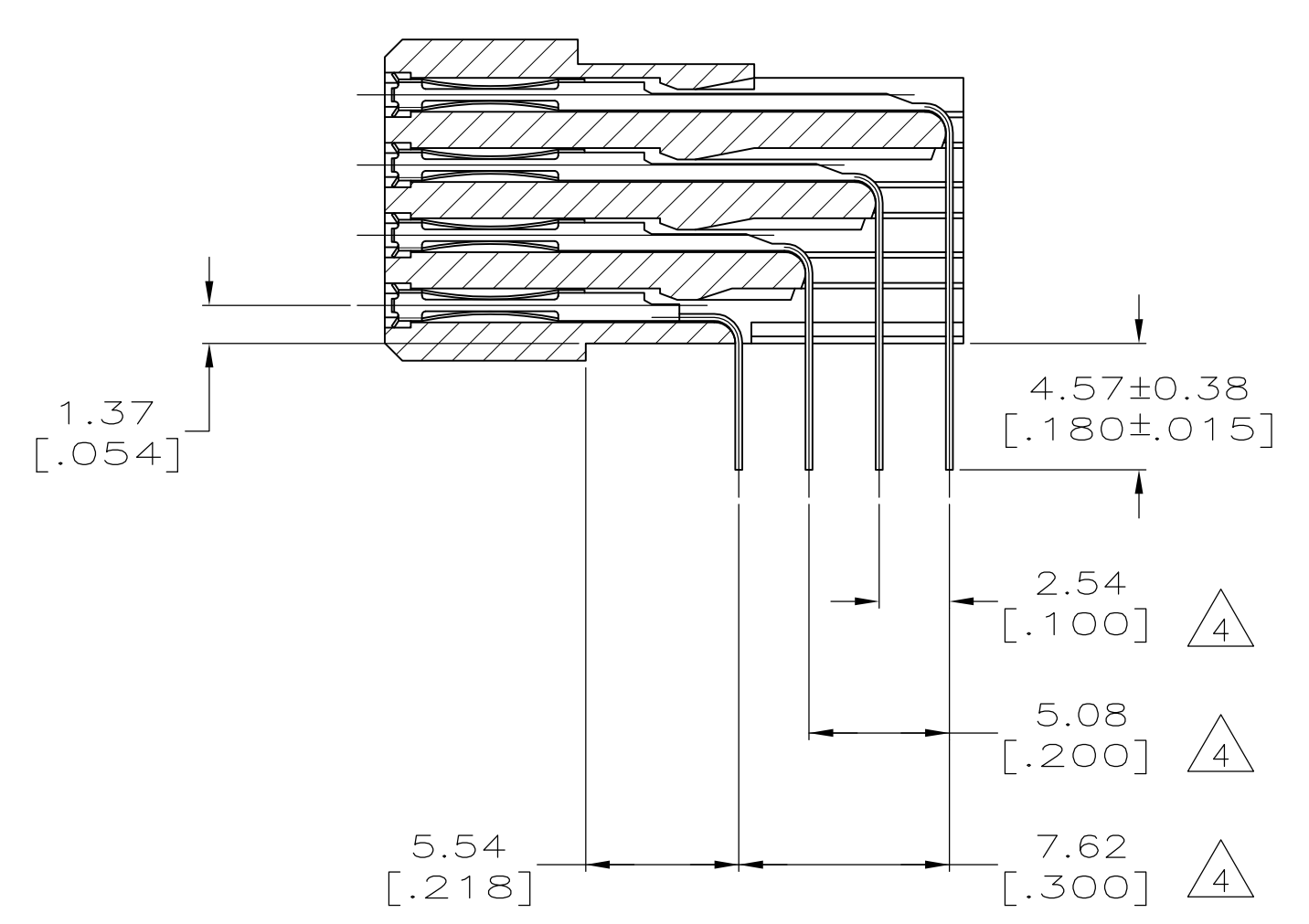
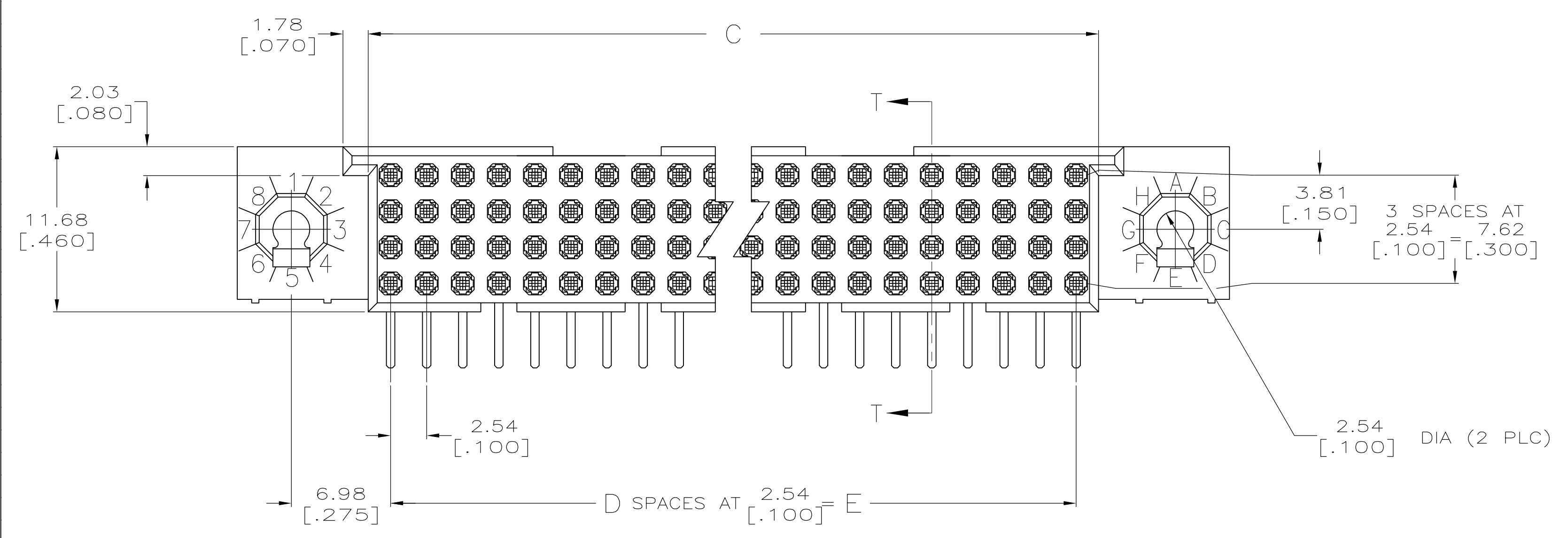
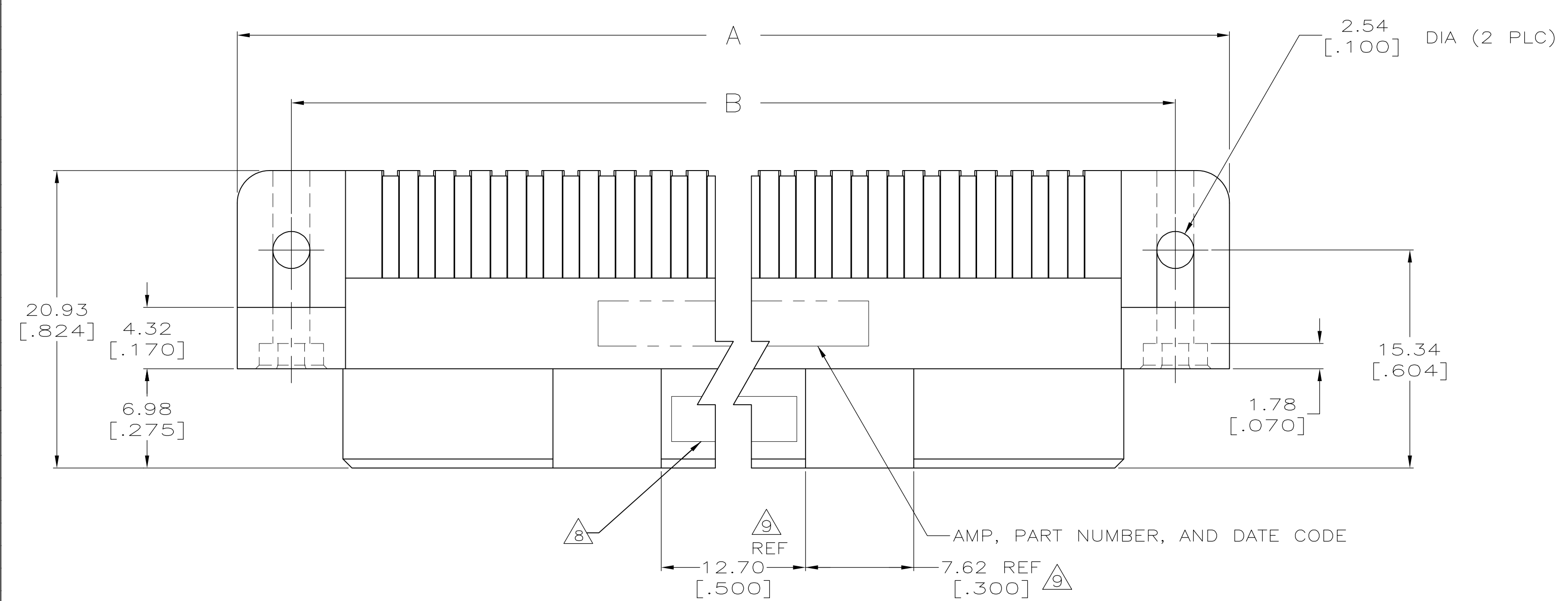

THIS DRAWING IS A CONTROLLED DOCUMENT.		DIN R.K. SEIFRIED 06/14/90		STE TE Connectivity	
DIMENSIONS: mm [INCHES]		CHK J.D.WEARY 02/26/92		NAME	
TOLERANCES UNLESS OTHERWISE SPECIFIED:		APVD		PRODUCT SPEC	
0 PLC ± -		-		APPLICATION SPEC	
1 PLC ± -		-		SIZE	
2 PLC ± -		-		CAGE CODE	
3 PLC ± 0.13 [.005]		-		DRAWING NO	
4 PLC ± -		-		RESTRICTED TO	
ANGLES ± -		-		WEIGHT	
MATERIAL		FINISH		A1 00779 C=532434	
1/2		3		CUSTOMER DRAWING	
		SCALE 4:1		SHEET 1 OF 2	
				REV S	

REVISIONS				
P	LTR	DESCRIPTION	DATE	APPV
-	-	SEE SHEET 1	-	-

- ① HOUSING MATERIAL: THERMOPLASTIC, COLOR: NATURAL.
- ② CONTACT MATERIAL: COPPER ALLOY.
- ③ FINISH:
MATING AREA: MEETS THE PERFORMANCE REQUIREMENTS OF PRODUCT SPECIFICATION 108-9063; BASED ON TELCORDIA DR-1217-CORE APPLICATIONS IN UNCONTROLLED ENVIRONMENTS.
SOLDER TAILS AREA: TIN-LEAD PLATED.
- ④ SOLDER TAILS MUST FIT HOLE PATTERN AS SHOWN ON THE RECOMMENDED P.C. BOARD LAYOUT.
- 5. DIMENSIONS IN BRACKETS ARE IN INCHES.
- ⑥ HOUSINGS WITH CENTER MOUNTING IS RECOMMENDED FOR ASSEMBLIES HAVING 75 CONTACTS OR MORE PER ROW.
- ⑦ OBSOLETE PART NUMBER.
- ⑧ DATE CODE MAY BE LOCATED IN THIS APPROXIMATE AREA FOR THIS PART NUMBER.
- ⑨ QUANTITIES OF VOID CORING ARE DEPENDENT ON THE POSITION SIZE OF THE HOUSING.

POSN	DESCRIPTION	DATE	APPV	REV			
7-8				2-532434-5			
7	48.26 [1.900]	19	51.41 [2.024]	62.23 [2.450]	69.85 [2.750]	80	2-532434-4
7-8	35.56 [1.400]	14	38.71 [1.524]	49.53 [1.950]	57.15 [2.250]	60	2-532434-3
7	160.02 [6.300]	63	163.17 [6.424]	173.99 [6.850]	181.61 [7.150]	256	2-532434-2
7-8	22.86 [.900]	9	26.01 [1.024]	36.83 [1.450]	44.45 [1.750]	40	2-532434-1
7	144.78 [5.700]	57	147.93 [5.824]	158.75 [6.250]	166.37 [6.550]	232	2-532434-0
7							1-532434-9
6-7							1-532434-8
6	238.76 [9.400]	94	241.91 [9.524]	252.73 [9.950]	260.35 [10.250]	380	1-532434-7
6	226.06 [8.900]	89	229.21 [9.024]	240.03 [9.450]	247.65 [9.750]	360	1-532434-6
6	213.36 [8.400]	84	216.51 [8.524]	227.33 [8.950]	234.95 [9.250]	340	1-532434-5
6-7	200.66 [7.900]	79	203.81 [8.024]	214.63 [8.450]	222.25 [8.750]	320	1-532434-4
6-7							1-532434-3
	187.96 [7.400]	74	191.11 [7.524]	201.93 [7.950]	209.55 [8.250]	300	1-532434-2
	175.26 [6.900]	69	178.41 [7.024]	189.23 [7.450]	196.85 [7.750]	280	1-532434-1
7	162.56 [6.400]	64	165.71 [6.524]	176.53 [6.950]	184.15 [7.250]	260	1-532434-0
	149.86 [5.900]	59	153.01 [6.024]	163.83 [6.450]	171.45 [6.750]	240	532434-9
	137.16 [5.400]	54	140.31 [5.524]	151.13 [5.950]	158.75 [6.250]	220	532434-8
	124.46 [4.900]	49	127.61 [5.024]	138.43 [5.450]	146.05 [5.750]	200	532434-7
	111.76 [4.400]	44	114.91 [4.524]	125.73 [4.950]	133.35 [5.250]	180	532434-6
	99.06 [3.900]	39	102.21 [4.024]	113.03 [4.450]	120.65 [4.750]	160	532434-5
	86.36 [3.400]	34	89.51 [3.524]	100.33 [3.950]	107.95 [4.250]	140	532434-4
	78.74 [3.100]	31	81.89 [3.224]	92.71 [3.650]	100.33 [3.950]	128	532434-3
7	73.66 [2.900]	29	76.81 [3.024]	87.63 [3.450]	95.25 [3.750]	120	532434-2
	60.96 [2.400]	24	64.11 [2.524]	74.93 [2.950]	82.55 [3.250]	100	532434-1
E	D	C	B	A	POSN	PART NUMBER	

THIS DRAWING IS A CONTROLLED DOCUMENT.		DIN R.K. SEIFRIED 06/14/90 CHK J.D. WEARY 02/26/92		 TE Connectivity	
DIMENSIONS: mm [INCHES]		TOLERANCES UNLESS OTHERWISE SPECIFIED:		NAME	
0 PLC ± - 1 PLC ± - 2 PLC ± - 3 PLC ± 0.13 [0.005] 4 PLC ± - ANGLES ± -		PRODUCT SPEC APPLICATION SPEC		HDI, 4 ROW, RECEPTACLE ASSEMBLY, 4.57 [180] LONG SOLDER TAILS	
MATERIAL ①②		FINISH ③		SIZE CASE CODE DRAWING NO A1 00779 532434	
WEIGHT 0		CUSTOMER DRAWING		SCALE 4:1 SHEET 2 OF 2 REV S	